

"EBS" FILTER SERIES

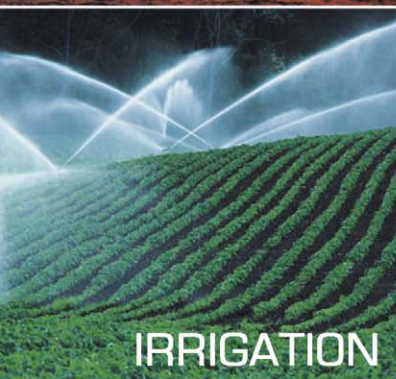

The largest automatic self-cleaning filter for fine filtration.

- ▶ For flow rates up to 4000 m³/h
- ▶ Fine filtration degrees: 800 - 10 micron
- ▶ Large filtration area of up to 40,000 cm²



AMIAD FILTRATION SYSTEMS

HOW THE "EBS" FILTERS WORK

The EBS is an automatic filter, with a self-cleaning mechanism driven by an electric motor. The EBS is designed to work with various types of screens in filtration degrees from 800 to 10 micron, and is available in 8" to 24" inlet/outlet diameter.

Filtering process:

Raw water flows into the filter through the cylindrical filter element from the inside-out, causing particles to accumulate on the inside screen surface which causes the development of a "filter cake". The accumulation of the filter cake causes pressure differential to develop between the filter inlet and outlet.

A pressure differential switch senses the pressure differential across the screen and when it reaches a pre-set value, the cleaning mechanism is operated.

Cleaning process:

The EBS begins the self-cleaning process when the pressure differential across the screen reaches a pre-set value or a pre-determined lapse of time. Cleaning of the filter's fine screen is carried out by the suction scanner which is a motor driven assembly that rotates while also moving linearly. It consists of a central tube with tubular nozzles equally spaced along the length of the central tube. An exhaust flush valve connects the internal cavity of the suction scanner to atmospheric pressure outside the filter body. By opening the exhaust valve, the differential pressure between the water inside the filter and the atmosphere outside the filter creates high suction forces at the openings of each of the suction scanner nozzles.

This suction force causes water to flow backwards through a small area of screen in front of each nozzle, pulling the filter cake off the screen and sucking it into the suction scanner and out through the exhaust valve to waste.

The driving mechanism rotates the suction scanner in a slow, controlled motion. The cleaning cycle is completed in approx. 30 seconds. During this time the nozzles cover 100% of the screen removing the filter cake from the entire screen surface. During the self-cleaning cycle, filtered water continues to flow downstream of the filter.

Control system:

The EBS filter is equipped with a pressure differential switch that transmits an electric signal to the electronic control board, which initiates the flush cycle.

A solenoid operates the exhaust valve by means of a hydraulic command or compressed air.

The filter operation and cleaning cycle is controlled and monitored by a Programmable Logic Control (PLC).

The PLC allows maximum flexibility in control options and has many features that can be incorporated per customer's needs.

The MegaEBS:

The MegaEBS filter consists of four EBS screen elements and cleaning mechanisms within one housing. An integral control panel allows for sequential operation of the cleaning mechanisms, one-by-one, in pairs, or all four units simultaneously.

The Mega EBS is an excellent solution for applications with space limitations or when limited number of filter units is required.

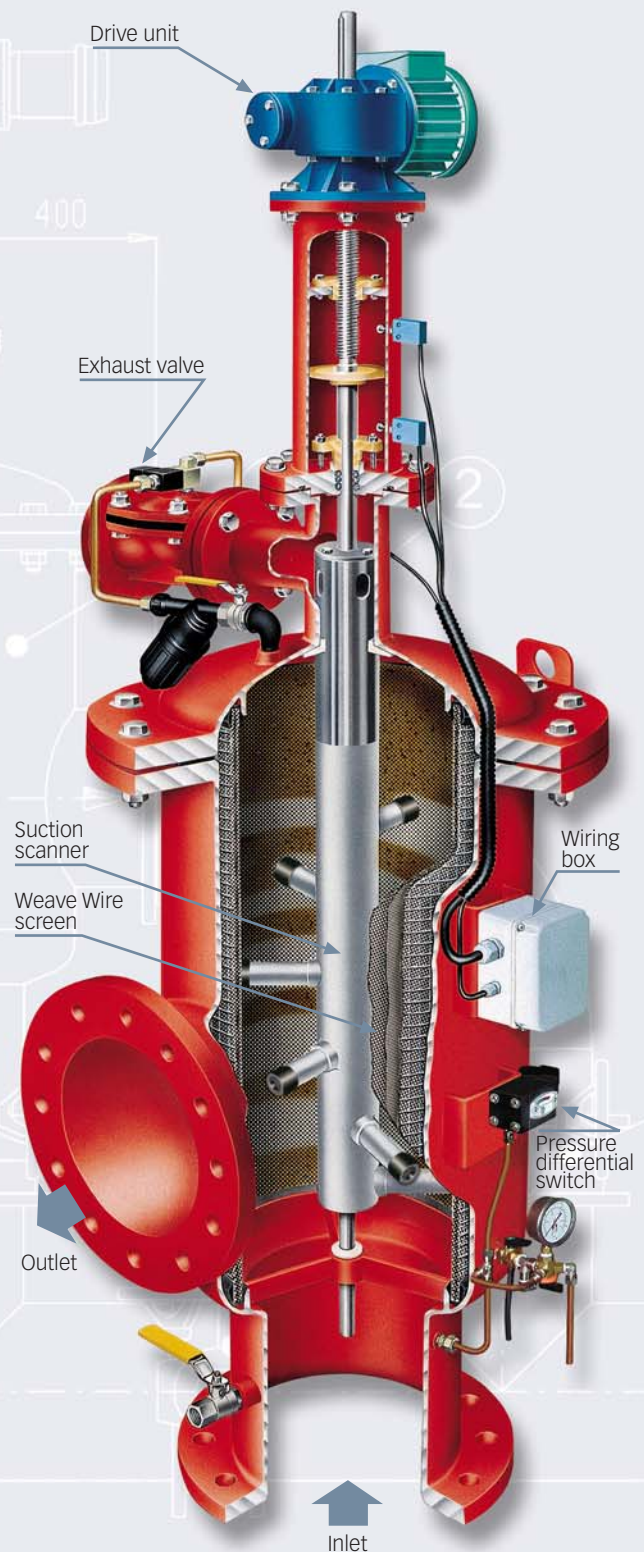

TECHNICAL SPECIFICATIONS

General

Filter type	EBS	MegaEBS	
Maximum flow rate [m ³ /h]	1,200	4,000	Consult manufacturer for optimum flow depending on filtration degree & water quality.
Min. working pressure [bar]	2	2	Pressure requirements depend on multiple factors. Please consult manufacturer.
Max. working pressure [bar]	10	10	16 bar upon request.
Filter area [cm ²]	10,000	40,000	
Inlet/Outlet diameter [mm] [inch]	200 - 400 8" - 16"	400 - 600 16" - 24"	Flange standards upon request.
Max. working temp. [°C]	60	60	95°C upon request.
Weight (Av.) empty [kg]	350	2,250	
Volume (Av.) [lit]	200	2,800	

Flushing data

Exhaust valve [mm]; [inch]	80; 3"	4 x 80; 3"	
Wasted water per cycle [lit]	500	2,000	at 2 bar
Min. flow for flushing [m ³ /h]	50	200-50	at 2 bar
Flushing cycle time [sec.]	35-40	30-120	at 50 Hz

Control and electricity

Electric motor [HP]	1/2	4 x 1/2	20/24 Gear output RPM
Control voltage [V]	24 AC		
Rated operation voltage	3 phase, 380 / 440 V 50/60Hz		
Current consumption [Amp.]	1.5	5.0	

Construction materials*

Filter housing and lid	Epoxy-coated carbon steel 37-2
Screens	Four-layer Weave Wire stainless steel 316L
Cleaning mechanism	Stainless steel 316L, Acetal
Exhaust valve	Epoxy-coated cast iron, Natural rubber
Seals	Synthetic rubber, Teflon
Control	Aluminum, Brass, Stainless steel, Nylon, PVC

*Amiad offers a variety of construction materials. Consult manufacturer for specifications.

Standard filtration degrees

	Weave Wire stainless steel screen									
micron	800	500	300	200	130	100	80	50	25	10
mm	0.8	0.5	0.3	0.2	0.13	0.1	0.08	0.05	0.02	0.01
mesh	20	30	50	75	120	155	200	300	450	600

SUGGESTED INSTALLATIONS

EBS

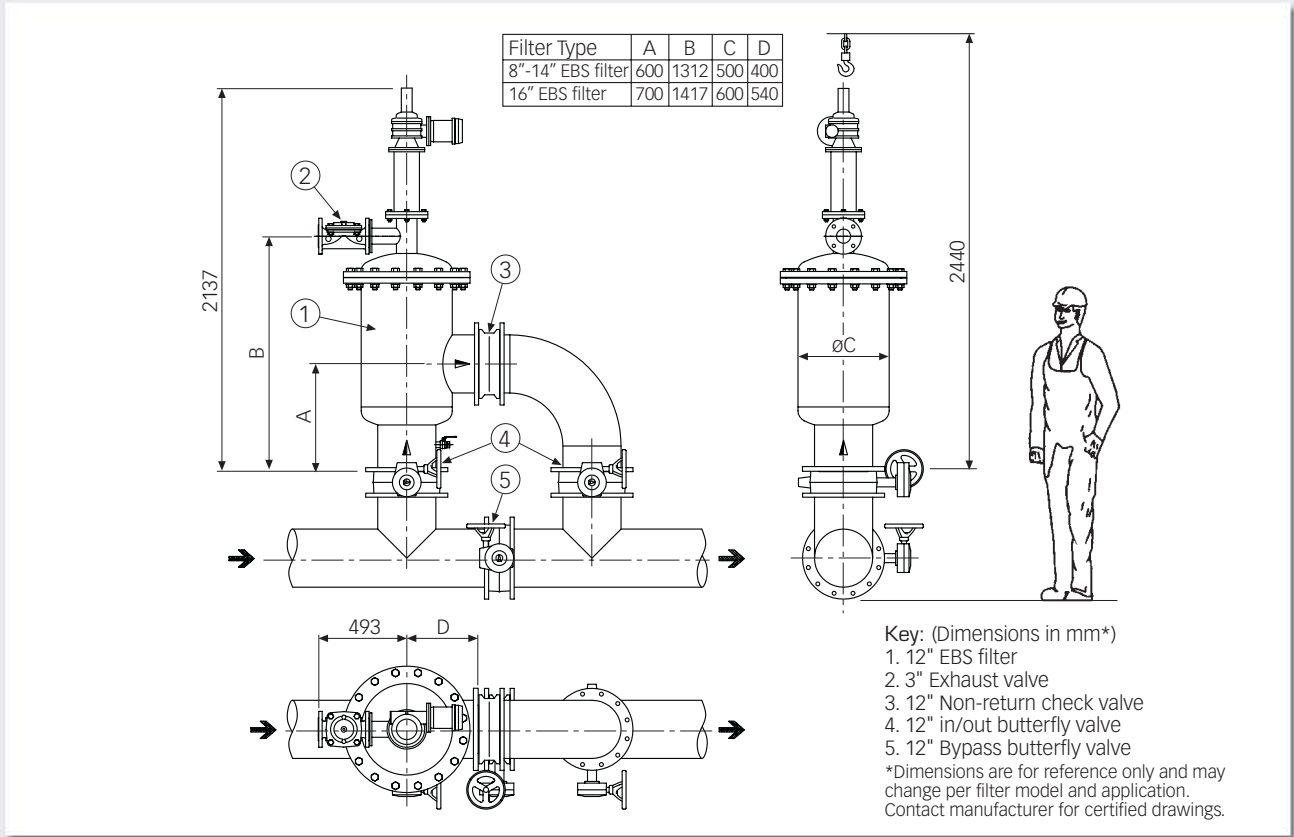

MegaEBS

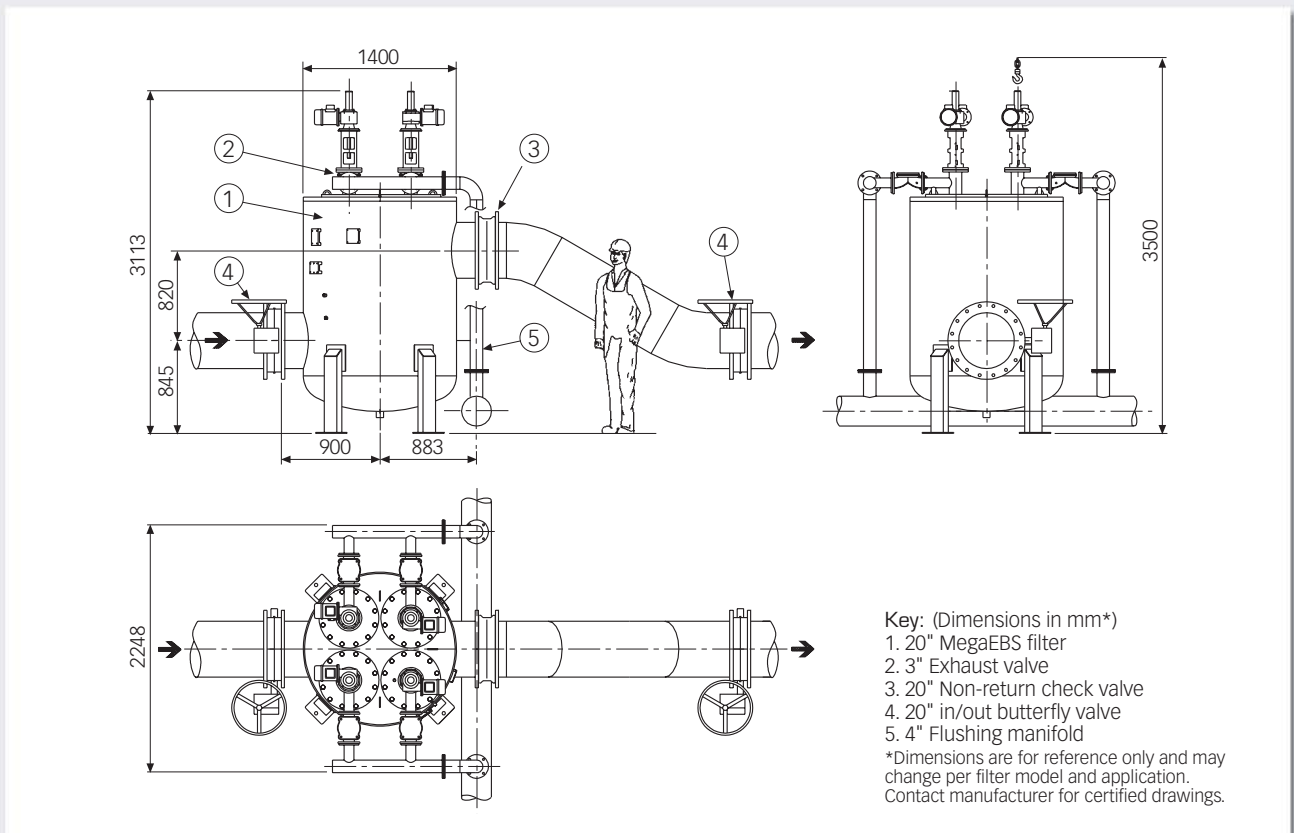

PRESSURE LOSS GRAPHS

EBS



MegaEBS

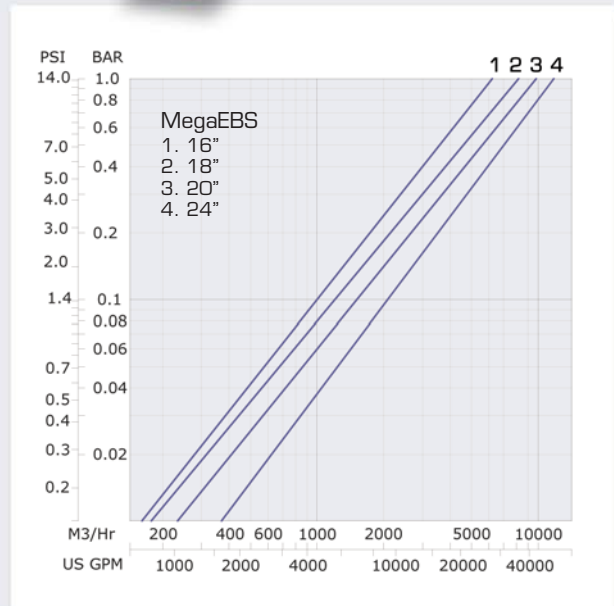
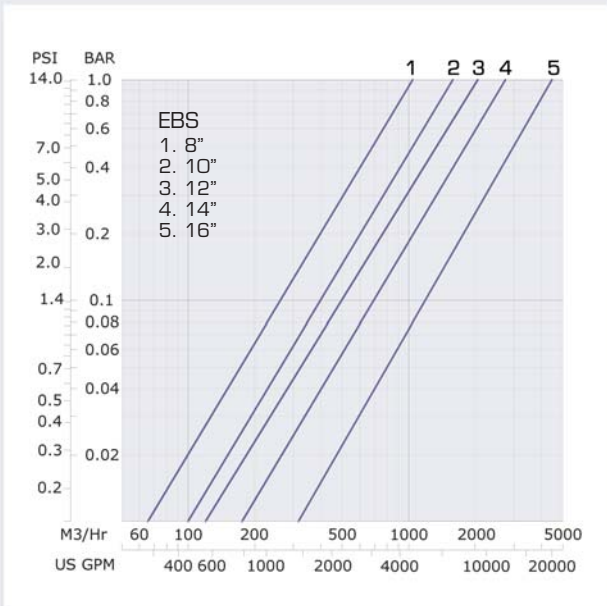

SELECTED WORLDWIDE APPLICATIONS



▲ Pre-filtration to DWTP. 375m³/h, 50µm. Dan river, Israel



▲ Injection water on board FPSO. 220m³/h, 25µm. West Africa



▲ Drip irrigation. 9000 m³/h, 130µm. China



▲ Drip irrigation of strawberries. 14,000m³/h, 130µm. Spain



▲ Golf course irrigation. 700m³/h, 200µm. Tampa, USA



▲ Irrigation water supply. 1800m³/h, 50µm. Narbonne, France



▲ Drip irrigation. 8000m³/h, 130µm. Helche Creviente, Spain



▲ Recreation and irrigation water supply. 3400 m³/h, 80µm. Spanish Fork, USA

SELECTED WORLDWIDE APPLICATIONS



▲ Aquaculture - Zebra mussel control. 2000m³/h, 25µm. Vermont, USA



▲ Cooling water in chemical plant. 460m³/h, 130µm. Hamburg, Germany



▲ Reservoir water for irrigation. 1000m³/h, 100µm. Kfar Hasidim, Israel



▲ Industrial wastewater. 800m³/h, 50µm. Electronic industry, Korea



▲ Injection water. 2000m³/h, 50µm. North Sea Platform



▲ River water for hot spa. 170m³/h, 25µm. Japan



▲ Pre-filtration to RO membranes. 1700m³/h, 25µm. Desalination plant, Israel



In an increasingly crowded world, the need for clean water concerns everyone involved in sustaining our quality of life. Society and economy cannot exist without water; Because water is life.

For more than 40 years, Amiad has helped meet this need by developing a comprehensive line of exceptionally efficient, automatic self-cleaning filters and manual filters for use in industry, municipalities, and irrigation. Amiad provides solutions in more than 66 countries, with seven subsidiaries and sales offices. Amiad's pledge to the filtration industry is to continue providing innovative and dependable systems, quality service and reliable customer support.

▶ **MANUFACTURER & HEAD OFFICE:**
Amiad Filtration Systems (1997) Ltd.

D. N. Galil Elyon 1, 12335, Israel, Tel: 972 4 690 9500, Fax: 972 4 690 9391, E-mail: info@amiad.com

▶ **AUSTRALIA:**

Amiad Australia Pty Ltd., 3/15 Brisbane St. Eltham, 3095, Victoria
Tel: 61 39 439 3533, Fax: 61 39 439 1612, E-mail: amiad@amiad.com.au

▶ **CHINA:**

Taixing Environtec Co. Ltd., 70 Baihe Chang, Xingjie Yixing Jiangsu, 214204
Tel: 86 0510 7134000, Fax: 86 0510 7134999, E-mail: taixing@public1.wx.js.cn

▶ **FAR-EAST:**

Filtration & Control Systems Pte. Ltd., 111 North Bridge Road #07-07, Peninsula Plaza, 179098, SINGAPORE
Tel: 65 6 337 6698, Fax: 65 6 337 8180, E-mail: fcs1071@pacific.net.sg

▶ **FRANCE:**

Amiad France S.A.R.L., 31 Boulevard Lefebvre, Paris, 75015
Tel: 33 1 56085522, Fax: 33 1 45302596, E-mail: info@amiadfrance.com

▶ **GERMANY:**

Amiad Filtration Solutions Ltd., Zweigniederlassung Deutschland, Gerstäckerstr. 9, D-20459
Tel: 49 40 3609 6770, Fax: 49 40 3609 6765, E-mail: info@amiad.de

▶ **NORTH AMERICA:**

Amiad Filtration Systems, 2220 Celsius Avenue Unit B., Oxnard, 93030, California, USA
Tel: 1 805 988 3323, Fax: 1 805 988 3313, E-mail: info@amiadusa.com

▶ **SOUTH AMERICA:**

Sucursal Sudamerica, Agustín de Urubey 1379, Montevideo, 11300, URUGUAY
Tel: 598 2 628 0927, Fax: 598 2 622 6991, E-mail: amisur@adinet.com.uy

www.amiad.com

AMIAD products undergo constant monitoring for quality control.
The manufacturer reserves the right to incorporate changes and improvements in the products without prior notice.



AMIAD FILTRATION SYSTEMS